

ONKYO SERVICE MANUAL

SYNTHESIZED FM STEREO/AM TUNER MODEL T-4120

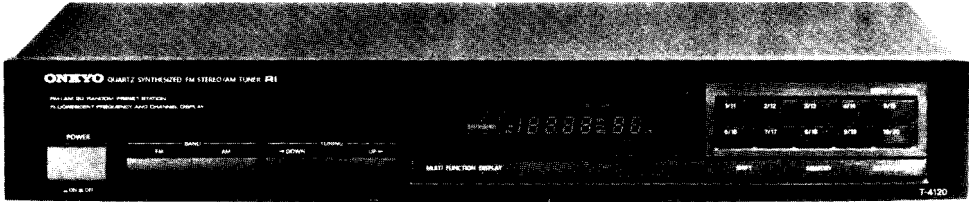

Black model

BUDN, BUD	120V AC, 60 Hz
BUG	220V AC, 50Hz
BUU, BUUX	110/120/220/240V AC, 50/60Hz
BUQA, BUQB	240V AC, 50 Hz

SAFETY-RELATED COMPONENT WARNING!!
COMPONENTS IDENTIFIED BY MARK Δ ON THE SCHEMATIC DIAGRAM AND IN THE PARTS LIST ARE CRITICAL FOR RISK OF FIRE AND ELECTRIC SHOCK. REPLACE THESE COMPONENTS WITH ONKYO PARTS WHOSE PART NUMBERS APPEAR AS SHOWN IN THIS MANUAL.

MAKE LEAKAGE-CURRENT OR RESISTANCE MEASUREMENTS TO DETERMINE THAT EXPOSED PARTS ARE ACCEPTABLY INSULATED FROM THE SUPPLY CIRCUIT BEFORE RETURNING THE APPLIANCE TO THE CUSTOMER.

TABLE OF CONTENTS

- Specifications 2
- Service procedures 2
- Block diagram 3
- Exploded view 4
- Parts list 5
- Block diagram of IC 6
- Packing view 10
- Adjustment procedures 11
- Pc board view/parts list 13
 - Main circuit 13
 - Display/Operation switch 19
- Schematic diagram 15
 - 120V model 15
 - Other models 17



SPECIFICATIONS

FM:		Harmonic Distortion:	Mono: 0.1%
Tuning Range:	87.9-107.9MHz(200kHz steps: U.S.A model) 87.5-108.0MHz(50kHz steps: European model) 87.9-107.9MHz(200kHz steps) or 87.5-108.0MHz(50kHz steps) (Worldwide model)	Stereo: 0.2%	
Usable Sensitivity:	Mono: 11.2dBf, 1.0 μ V IHF 0.9 μ V 75ohms DIN	Frequency Response:	30-15,000Hz \pm 1.5dB
	Stereo: 2.0 μ V 75ohms	Stereo Separation:	40dB at 1kHz 30dB at 70-10,000Hz
50dB Quieting Sensitivity:	Mono: 11.2dBf, 2.0 μ V IHF (120V model) Stereo: 17.2dBf, 4.0 μ V (120V model)	Muting Level:	2.0 μ V, 75ohm 17.2dBf, 4.0 μ V
	Mono: 1.7 μ V 75ohms	Output Voltage:	500mV (120V model) 750mV (Other models)
	Stereo: 1.7 μ V 75ohms	AM:	
Capture Ratio:	1.5dB	Tuning Range:	530-1620kHz(10kHz steps) (U.S.A. model) 522-1611kHz(9Hz steps) (European model) 530-1620kHz(10kHz steps) or 531-1602kHz(9kHz steps) (Worldwide model)
Image Rejection Ratio:	40dB (120V model) 80dB (Other models)	Usable Sensitivity:	25 μ V
IF Rejection Ratio:	90dB	Image Rejection Ratio:	40dB
Signal-to-Noise Ratio:	Mono: 73dB Stereo: 66dB	IF Rejection Ratio:	40dB
Alternate Channel		Signal-to-Noise Ratio:	40dB
Attenuation:	50dB IHF (\pm 400kHz) (120V model)	Harmonic Distortion:	0.8%
Selectivity:	55dB DIN (\pm 300kHz, 40kHz dev.) (Other models)	Output voltage:	150mV
AM suppression Ratio:	50dB	GENERAL:	
		Dimensions(W \times H \times D):	435 \times 71 \times 265mm 17-1/8" \times 2-7/8" \times 10-3/8"
		Weight:	2.6kg., 5.71bs.

Specifications and features are subject to change without notice.

SERVICE PROCEDURES

1. Safety-check out

(Only U.S.A. model)

After correcting the original service problem, perform the following safety check before releasing the set to the customer.

Connect the insulating-resistance tester between the plug of power supply cord and chassis.

Specifications: 3.3Mohm \pm 10% at 500V.

2. Memory preservation

This unit does not require memory preservation batteries. A built-in memory power back-up system preserves contents of the memory during power failures and even when the unit is unplugged. The unit must be plugged in and the power switch turned on and off once in order to charge the back-up system. Note that since this is not a permanent memory, the power switch must be turned on and off a few times each month to keep the back-up system operative. The period of time during which memory contents are preserved after power has last been turned off varies depending on climate and placement of the unit.

On the average, memory contents are protected over a period of 3 to 4 weeks (a minimum of 2 weeks) after the last time power has been turned off. This period is shorter when the unit is exposed to very high humidity or used in an area with an extremely humid climate.

3. Voltage Selector (Back Panel)

W models are equipped with a voltage selector to conform with local power supplies. Be sure to set this switch to match the voltage of the power supply in your area before turning the power switch on. This switch is set to 220V at the factory. Voltage is changed by sliding the groove in the switch with a screwdriver to the right or left. Confirm that the switch has been moved all the way to the right or left before turning the power switch on. Models without a voltage selector can only be used in areas where the power supply is the same as that of the unit.

4. Tuning Step Frequency Switch (Back Panel)

W models are equipped with a switch for the AM (9kHz/10kHz) and FM (50kHz/100kHz) bands. The switch should be set to the proper steps for the radio broadcast frequencies in your area.

5. Changing the band step

With the exception of the models below, a BAND STEP selector switch is not provided.

MODEL	BAND STEP	D767	R118
UD	200kHz \rightarrow 50kHz	Eliminated	15k Ω \rightarrow 30k Ω
UG/UQ	50kHz \rightarrow 200kHz	Additional	30k Ω \rightarrow 15k Ω

In D767, 1SS133 (Part No. 223163) is used. R118, with the muting amplitude determined, is on the back panel side of the main circuit printed circuit board assembly test points TP-1 and TP-2.

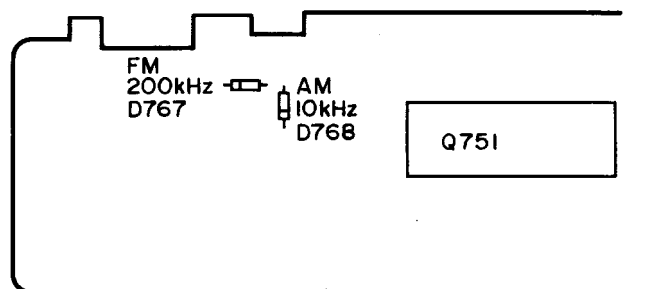

BLOCK DIAGRAM

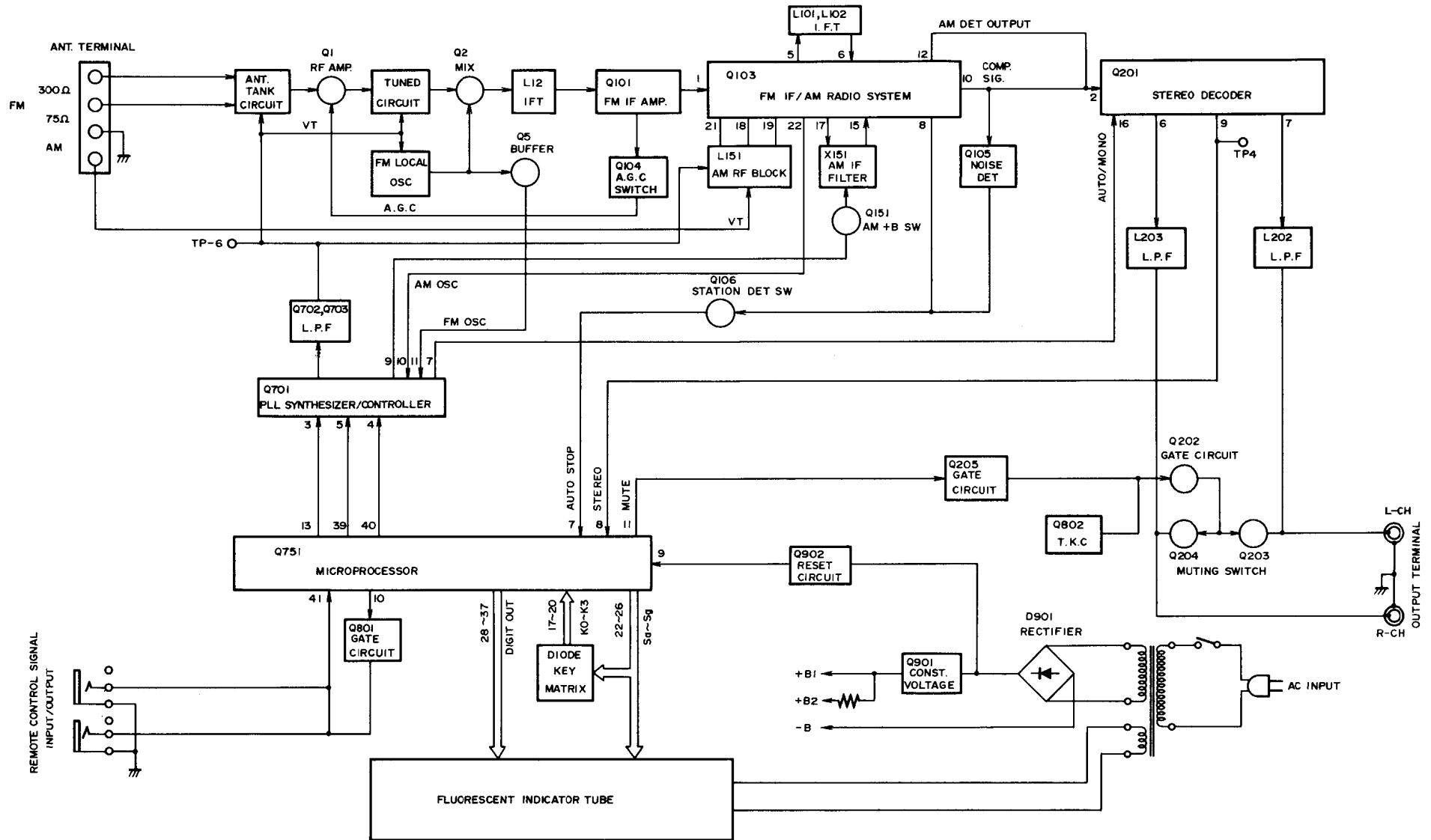

EXPLODED VIEW

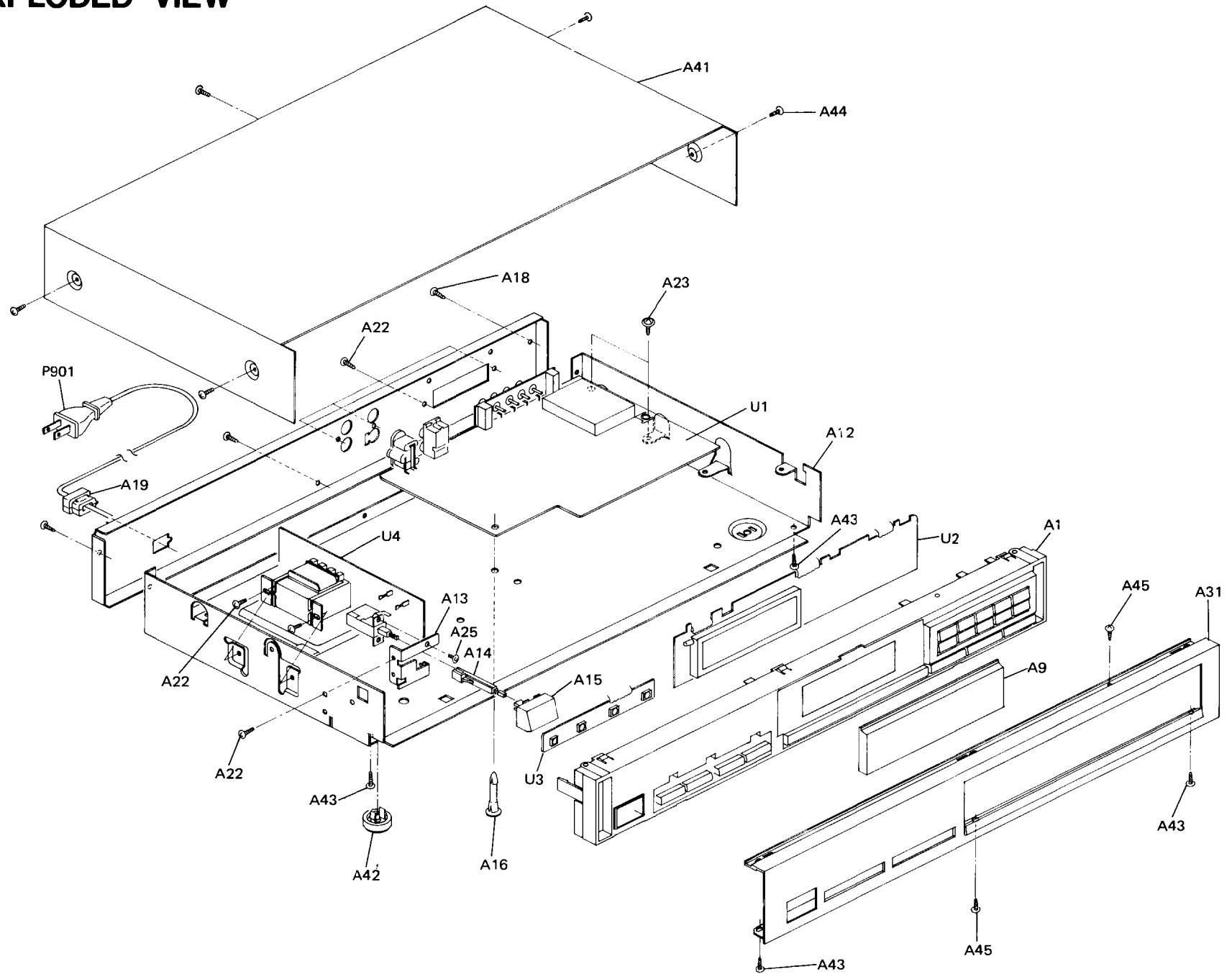

PARTS LIST

REF. NO.	PART NO.	DESCRIPTION
A1	27110398B	Front bracket
A9	28191458C	Clear plate
A12	27100116-1	Chassis
A13	27141254	Bracket, power
A14	27260170A	Joint, switch
A15	28323241	Knob POWER
A16	27190511	Holder
A18	27121073	Back panel <D>
	27121074	Back panel <G>
	27121087	Back panel <W>
	27121171	Back panel <QA/QB>
A19	27300750	△ Strainrelief
A22	834430088	3TTS + 8B(BC), Tapping screw
A23	831130088	3TTW + 8B, Tapping screw
A25	82143006	3P + 6FN(BC), Pan head screw
A31	1A083121	Front panel ass'y
A41	28184350A	Top cover
A42	27175130	Leg
A43	833430080	3TTP + 8P(BC), Tapping screw
A44	834430088	3TTS + 8B(BC), Tapping screw
A45	838430088	3TTB + 8B(BC), Tapping screw
P901	253142A	△ AS-UC-7 # 18, Power supply cord <D>
	253148	△ AS-CEE, Power supply cord <G/W>
	253118	△ AS-SAA, Power supply cord <QA>
	253104	△ Power supply cord <QB>
S902	25065123	△ NSS-1258P, Voltage selector switch <W>
U1	1A082561-1	NARF-3261-1, FM/AM tuner pc board ass'y <D>
	1A082561-1A	NARF-3261-1A, FM/AM tuner pc board ass'y <G/QA/QB>
	1A083561-1B	NARF-3261-1B, FM/AM tuner pc board ass'y <W>
U2	1A082562-1	NADIS-3262-1, Display circuit pc board ass'y <D>
	1A082562-1A	NADIS-3262-1A, Display circuit pc board ass'y <G>
	1A083562-1B	NADIS-3262-1B, Display circuit pc board ass'y <W>
U3	1A082563-1	NASW-3263-1, Switch pc board ass'y
U4	1A082564-1	△ NAPS-3264-1, Power supply circuit pc board ass'y <D>
	1A082564-1A	△ NAPS-3264-1A, Power supply circuit pc board ass'y <G>
	1A083564-1B	△ NAPS-3264-1B, Power supply circuit pc board ass'y <W>
	1A083564-1C	△ NAPS-3264-1C, Power supply circuit pc board ass'y <QA/QB>

NOTE: <D>:Only 120V model
 <G>:Only 220V model
 <W>:Only Worldwide model
 <QA>:Australian model
 <QB>:British model

NOTE: THE COMPONENTS IDENTIFIED BY MARK △ ARE CRITICAL FOR RISK OF FIRE AND ELECTRIC SHOCK. REPLACE ONLY WITH PART NUMBERS SPECIFIED.

LM7001 (PLL frequency synthesizer)

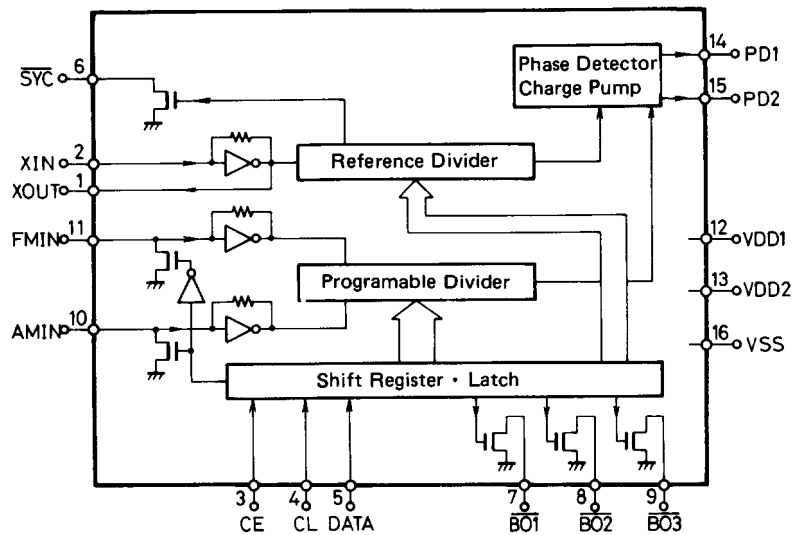

Pin No.	Terminal	Description									
1	XOUT	Connect to the 7.2 MHz crystal oscillator.									
2	XIN										
3	CE	Chip enable terminal. Connect to the PLL terminal of μ PD7538ACU-218.									
4	CL	Serial clock input terminal. Connect to the CLOCK terminal of μ PD7538ACU-218.									
5	DATA	Serial data input terminal. Connect to the DATA terminal of μ PD7538ACU-218.									
6	SYN	Not used.									
8	BAND1	Band selector output terminal.									
9	BAND2										
		<table border="1"> <thead> <tr> <th>BAND</th> <th>BAND 1</th> <th>BAND 2</th> </tr> </thead> <tbody> <tr> <td>FM</td> <td>L</td> <td>H</td> </tr> <tr> <td>AM</td> <td>H</td> <td>L</td> </tr> </tbody> </table>	BAND	BAND 1	BAND 2	FM	L	H	AM	H	L
BAND	BAND 1	BAND 2									
FM	L	H									
AM	H	L									
7	BO1	This is the output terminal for AUTO/MONO. 'H' when AUTO.									
10	AMIN	AM local oscillator input terminal.									
11	FMIN	FM local oscillator terminal.									
12	VDD 1	Power supply terminal for back-up.									
13	VDD 2	Power supply terminal.									
14	PD1	Charge pump output of the phase detector which constitutes the PLL. High level is output when the divided local oscillator frequency is high than the reference frequency.									
15	PD2	In the opposite case, low level is output. Floating occurs when the frequencies matched. The output is applied to the variable capacitor diode in the local oscillator through the low pass filters.									
16	Vss	Ground terminal.									

μPD7538ACU-218 (Microprocessor)

Terminal Descriptions

Pin No.	Terminal	Description
1	RESET	Reset signal input terminal. "H" when active.
2	CL1	Connect to the 600kHz ceramic oscillator.
3	CL2	
4	VPRE	Power source supply terminal for output buffer of FIP controller/driver.
5	VLOAD	Pull down resistor connection terminal for FIP controller/driver.
6	STANBY	Stand by input terminal. "L" when active.
7	AUTO STOP	Auto stop signal input terminal. Auto tuning stops when this terminal becomes the high level.
8	STEREO	Stereo broadcast detector input terminal. "L" when stereo broadcast.
9	POWER OFF	This is the input terminal for detection of the stoppage of electric current. "L" when the stoppage of electric current.
10	SYSTEM OUT	System code output terminal. "L" when active.
11	MUTE	This is the output terminal for muting control. "L" when active.
12	AUTO/MONO	This is the output terminal for AUTO/MONO switching. "H" when active.
13	CE	Connect to the terminal CE of PLL IC(LM7001).
14	AM	This is the output terminal for AM band control. "H" when AM band.
15	FM	This is the output terminal for FM band control. "H" when FM band.
16	DISPLAY	This is the display output terminal.
17	K0	These are the input terminal for key return signal source and diode matrix signal. "H" when active.
18	K1	
19	K2	
20	K3	
21	VDD	This is the device power source terminal. At the time of operation, the supply is 5V. The internal date memory(RAM) is maintained by means of the supper capacitor.
22	D7	These are the digit signal and key scan output terminals. "H" when active.
23	D6	
24	D5	
25	D4	
26	D3	
27	D2	
28	D1	
29	Si	These are the segment terminals. "H" when active.
30	Sh	
31	Sg	
32	Sf	
33	Se	
34	Sd	
35	Sc	
36	Sb	
37	Sa	
38		Not used.
39	DATE	Serial date output terminal for PLL IC(LM7001).
40	CLOCK	Serial clock output terminal for PLL IC(LM7001).
41	SYSTEM IN	System code input terminal. "H" when active.
42	Vss	Ground terminal.

Key and diode matrix

	D1 (28)	D2 (27)	D3 (26)	D4 (25)	D5 (24)	D6 (23)	D7 (22)
K3(20)	P4	P8	MEMORY	AM		SYS DIS	
K2(19)	P3	P7	SHIFT	FM	P.SCAN	AM9	AUTO/MONO
K1(18)	P2	P6	P10	UP	SLEEP	BAND 1	PRESET
K0(17)	P1	P5	P9	DOWN	AUTO/MONO	BAND 0	SLEEP
Diode matrix							

BAND 0/1(FM band setting)

BAND	BAND	Region	Frequency range	Channel space	Reference frequency	IF frequency
1	0	Region	Frequency range	Channel space	Reference frequency	IF frequency
0	0	Europen	87.50~108.00MHz	50kHz	25kHz	10.7MHz
0	1	U.S.A.	87.9 ~107.9MHz	200kHz	25kHz	10.7MHz
1	1	Saudi Arabia	87.50~108.00MHz	50kHz	25kHz	10.7MHz

AM

AM	Region	Frequency range	Channel space	Reference frequency	IF frequency
9	Region	Frequency range	Channel space	Reference frequency	IF frequency
0	Europen	522~1611 kHz	9kHz	9kHz	450kHz
1	U.S.A.	530 ~ 1620 kHz	10kHz	10kHz	450kHz
0	Saudi Arabia	351 ~ 1602 kHz	9kHz	9kHz	450kHz

FIP10BBM8 (Fluorescent tube)

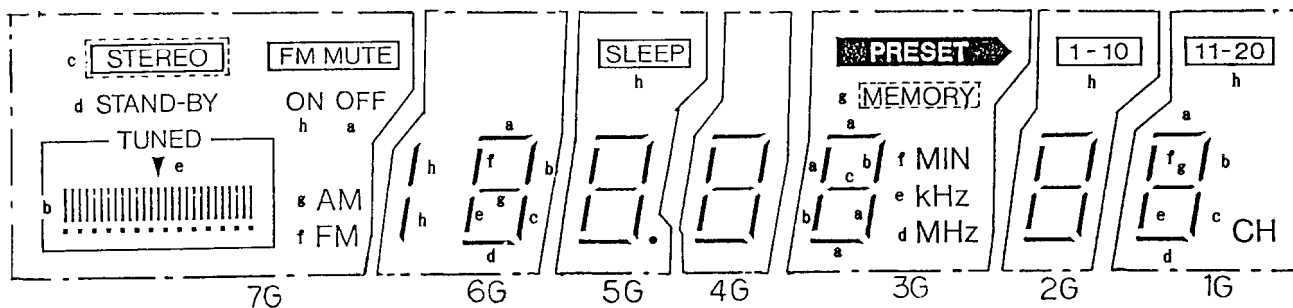

TERMINAL NO.	1	2	3	4	5	6	7	8	9	10	11	12	13	14	15	16	17	18	19	20
ELECTRODE	F	F	7G	P (S4)	P (i)	P (h)	7G	P (g)	P (S3)	P (S2)	7G	NC	6G	NP	NP	6G	NP	NP	5G	NP
TERMINAL NO.		21	22	23	24	25	26	27	28	29	30	31	32	33	34	35	36	37	38	39
ELECTRODE		NP	4G	NC	3G	NP	NP	P (f)	3G	P (e)	P (d)	2G	P (c)	P (b)	P (a)	1G	P (S1)	NP	F	F

Notes F: Filament NP: No Pin
 G: Grid NC: No Connection
 P: Anode

PACKING VIEW

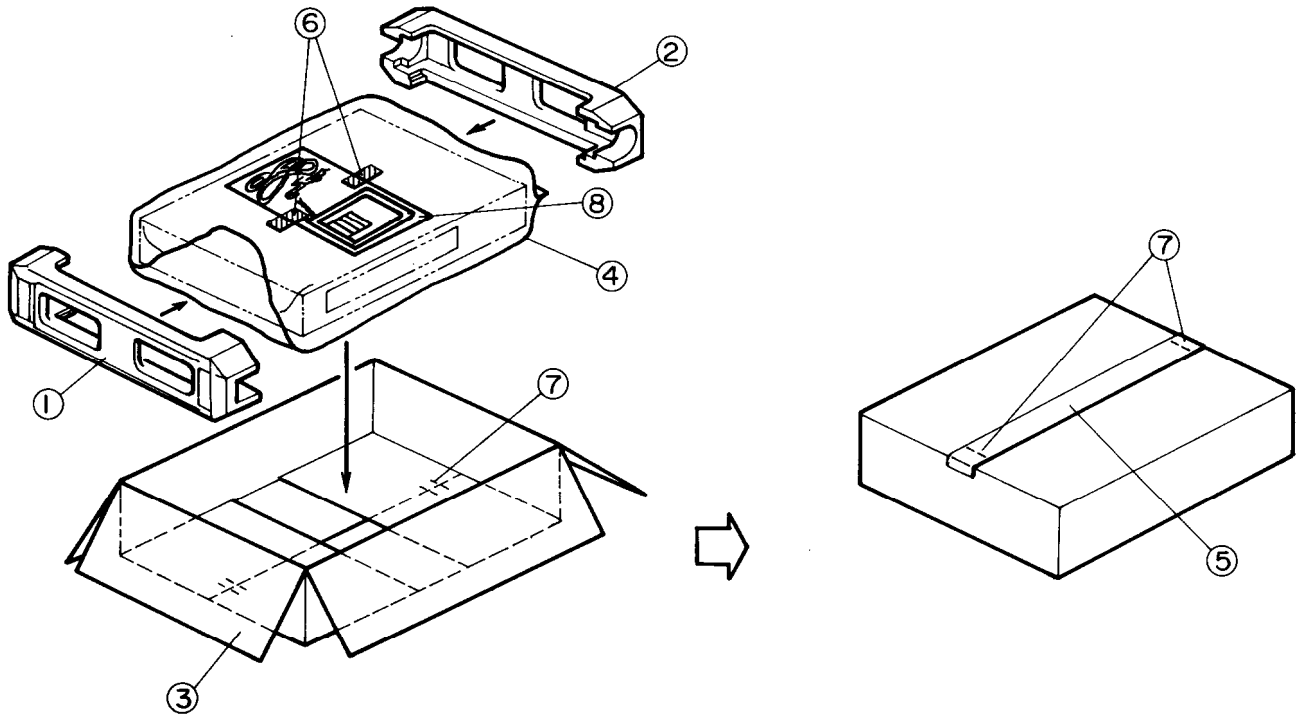

REF. NO.	PART NO.	DESCRIPTION
1	29090532B	Pad L
2	29090533F	Pad R
3	29051648	Master carton box
4	29100037A	650 × 500mm, Poly-vinyl bag
5	260012	50 × 700 mm, Damplon tape
6	261504	30 × 300 mm, Adhesive tape
7	282301	Sealing hook
8		Accessory bag ass'y
	120V model	
	29341224	Insutruccion manual
	292064B	FM antenna
	232140	NMA-3057, AM loop antenna
	2010098	Connection cord
	2010169	Connection cord for remote control
	29365019	Warranty card <Only U.S.A. model>
	29358002E	Service station list <Only U.S.A. model>
	29100006A	350 × 250mm, Poly-vinyl bag
	220V model	
	29341226	Insutruccion manual
	29341228	Insutruccion manual, Italian
	292092	FM antenna
	232140	NMA-3057, AM loop antenna
	2010098	Connection cord
	2010169	Connection cord for remote control
	29100006A	350 × 250mm, Poly-vinyl bag
	Worldwide model	
	29341226	Insutruccion manual
	29341228	Insutruccion manual, Italian
	292064B	FM antenna
	232140	NMA-3057, AM loop antenna
	2010098	Connection cord
	2010169	Connection cord for remote control
	25055018	CV-K-1, Conversion plug
	25060088	AE21-0050, FM adaptor
	29100006A	350 × 250mm, Poly-vinyl bag

ADJUSTMENT PROCEDURES

Preparation

• Input

FM mono: 1kHz, 75kHz devi., 60dB/μV (65dBf)
 FM stereo: 1kHz, L+R 67.5kHz devi.: Pilot signal 19kHz
 7.5kHz devi.
 AM: 400Hz, 30% mod.,

Reference specifications

Tuned voltage	AM	530 kHz (522kHz)	1.3 ± 0.4V
		1620 kHz (1611kHz)	7.5 ± 1.0V
	FM	87.9MHz	1.5 ± 0.5V
		107.9MHz	8.0 ± 0.5V
Muting level			10 ± 3dB
Muting width			35 ± 10kHz
Auto stop level	AM		Less than 68dB/m
	FM		Less than 16 dBμ
Stereo indicator level			Less than 17dBμ

FM Section

Item	Step	Connection of instrument	FM SG output	Stereo modulator output	Tuned frequency	Output indicator	Adjustment point	Adjust	Remarks
FM IF	1	Fig. 1	99.1 MHz, 1 kHz 75 kHz devi. 65 dBf (60 dB μ)		99.1 MHz	DC voltmeter	L101	0 ± 20 mV	Muting switch to MONO. Repeat the steps 1 and 2 until no further adjustment is necessary.
	Distortion analyzer					L102	Minimum		
Muting Level	1	Fig. 1	99.1 MHz, 1 kHz 75 kHz devi. 17.2 dBf (12 dB μ)	—	99.1 MHz	Oscilloscope	R101	Signal	
	2							16.2 dBf (11 dB μ)	
VCO		Fig. 2	99.1 MHz, 1 kHz 75 kHz devi. 65 dBf (60 dB μ)		99.1 MHz	Frequency counter	R201	19,000 ± 10 Hz	Muting switch to STEREO
Stereo Distortion		Fig. 3	99.1 MHz, Ext. modulation 65 dBf (60 dB μ)	L + R 1 kHz, 67.5 kHz devi. Pilot signal 7.5 kHz devi.	99.1 MHz	Distortion analyzer	IF core on front end	Minimum	

AM Section

Step	AM SG output	Tuned frequency	Output indicator	Adjust point	Adjust for
1		522 kHz (530 kHz)	Digital DC voltmeter	L151 OSC	1.3 ± 0.1V
2	603 kHz, 400 Hz 30% mod. 60 dB/m (600 kHz)	603 kHz (600 kHz)	AC voltmeter	L151 RF	Maximum
3	999 kHz, 400 Hz 30% mod. 60 dB/m (1000 kHz)	999 kHz (1000 kHz)	AC voltmeter	L152	Maximum

() : 10 kHz step model

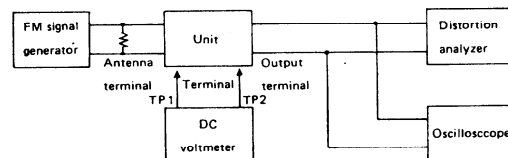

(fig. 1)

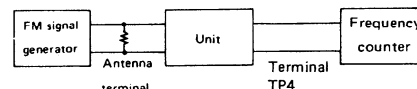

(fig. 2)

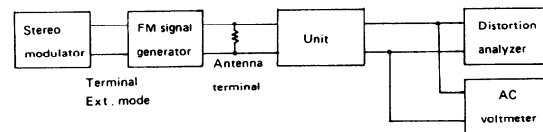

(fig. 3)

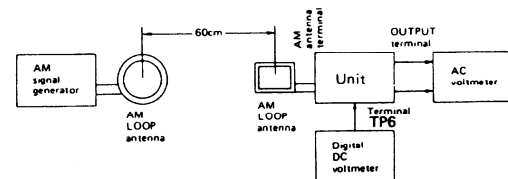

(AM)

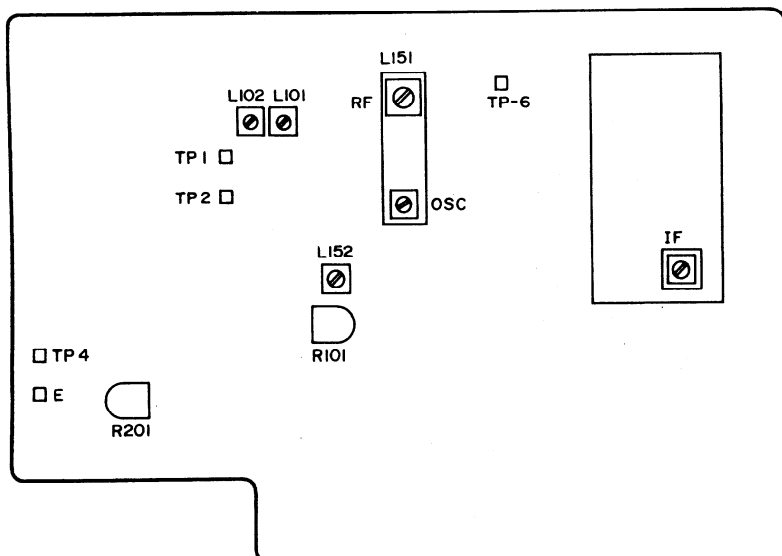

A

B

C

D

E

F

G

SCHEMATIC DIAGRAM

-other model-

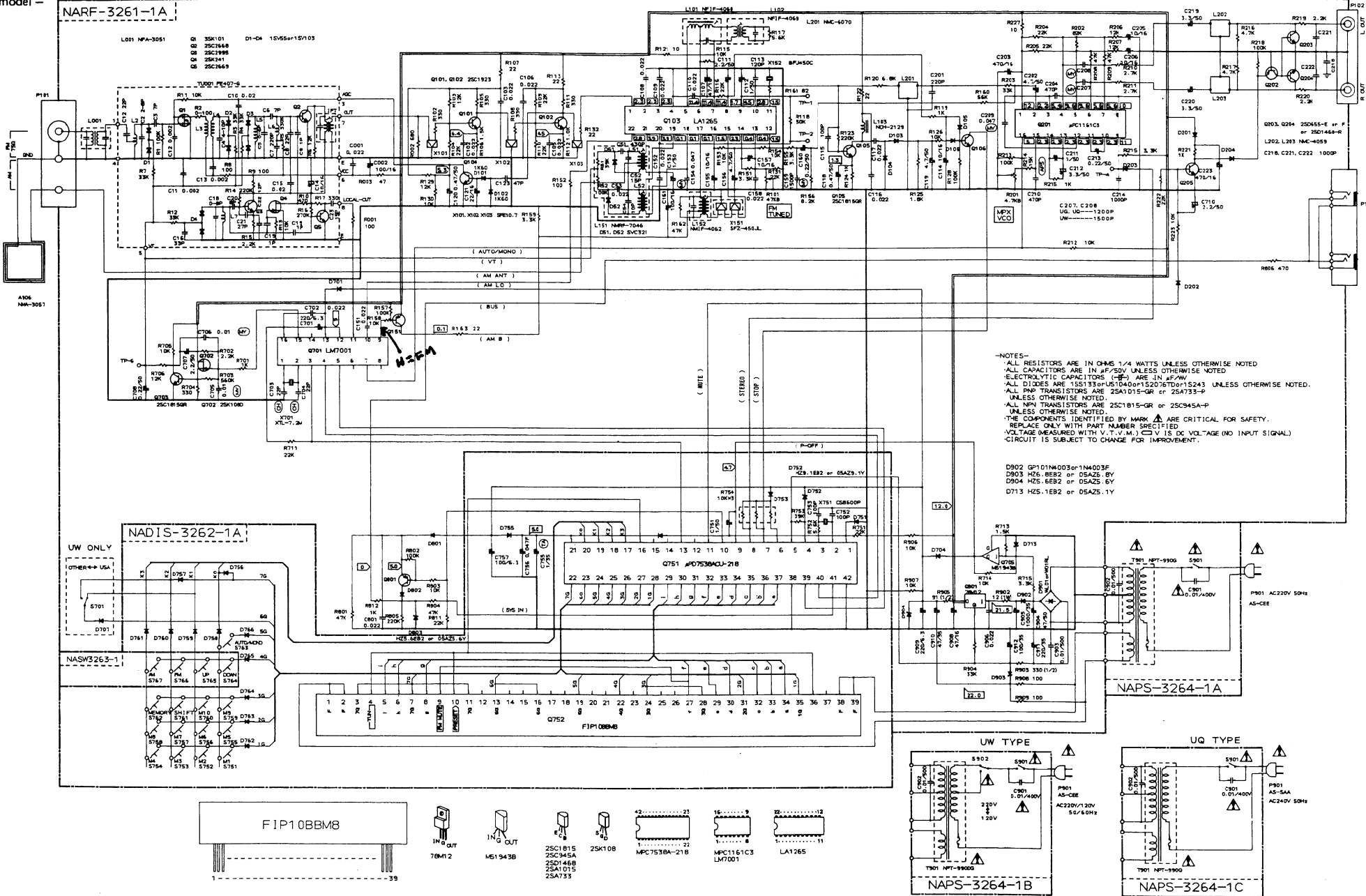

NOTES-

- ALL RESISTORS ARE IN OHMS 1/4 WATTS UNLESS OTHERWISE NOTED
- ALL CAPACITORS ARE IN $\mu\text{F}/50\text{V}$ UNLESS OTHERWISE NOTED
- ELECTROLYTIC CAPACITORS (E-C) ARE IN $\mu\text{F}/50\text{V}$
- ALL DIODES ARE 1S5133 or US1040 or 1S2076 or 1S243 UNLESS OTHERWISE NOTED.
- ALL PNP TRANSISTORS ARE 2SA1015-QR or 2SA733-P UNLESS OTHERWISE NOTED.
- ALL NPN TRANSISTORS ARE 2SC1815-QR or 2SC345A-P UNLESS OTHERWISE NOTED.
- THE COMPONENTS IDENTIFIED BY MARK Δ ARE CRITICAL FOR SAFETY. REPLACE ONLY WITH PART NUMBER SPECIFIED.
- VOLTAGE (MEASURED WITH V. T. M.) $\text{C}201$ V IS DC VOLTAGE (NO INPUT SIGNAL)
- CIRCUIT IS SUBJECT TO CHANGE FOR IMPROVEMENT.

D902 GP101M003 or 1M4003F
 D903 HZ6.8E2 or 05A25.6Y
 D904 HZ5.6E2 or 05A25.6Y
 D715 HZ5.1E2 or 05A25.6Y

A B C D E F G

SCHEMATIC DIAGRAM

- 120V model -

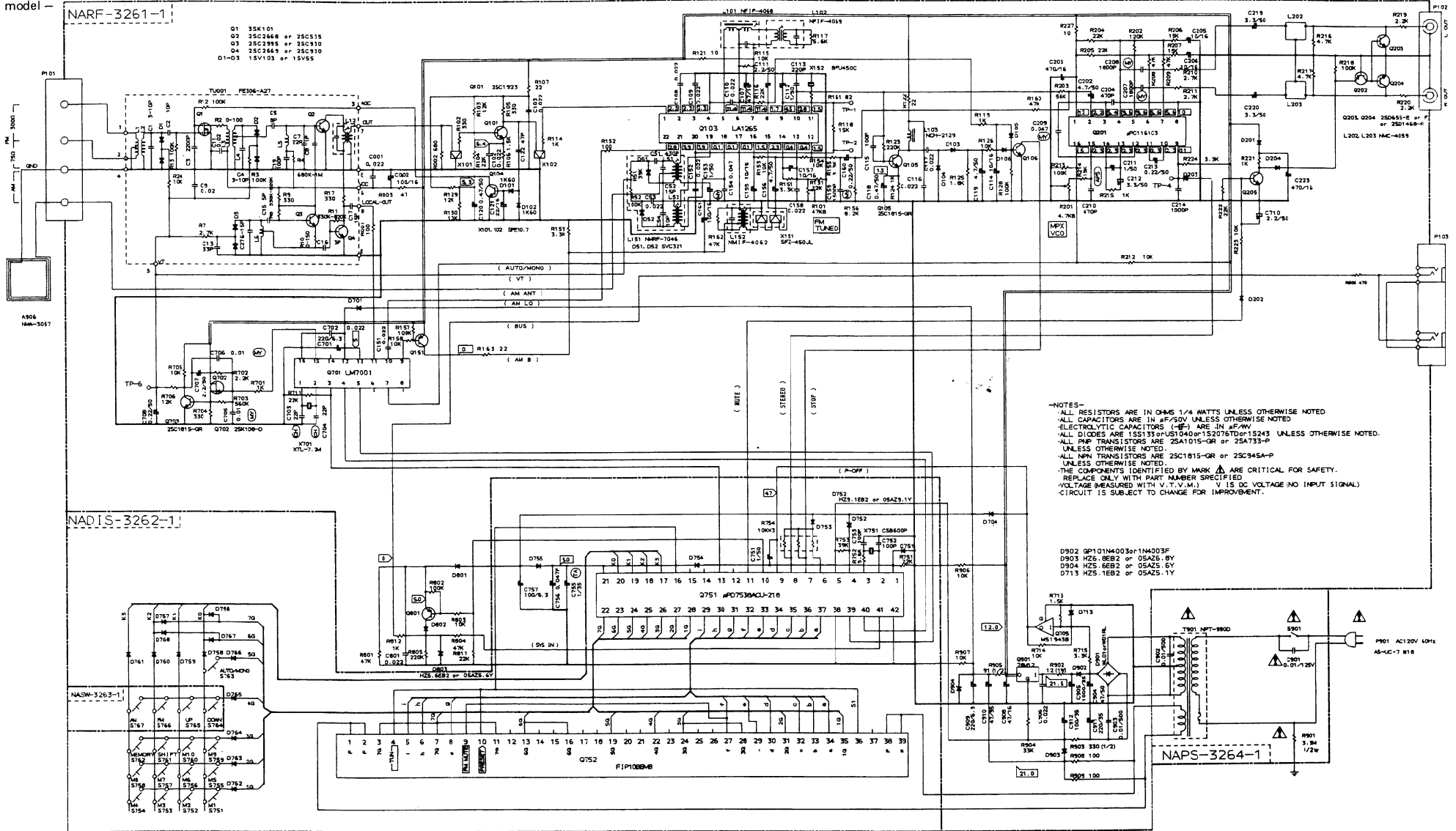

- Q1 3SK101
- Q2 2SC2668 or 2SC535
- Q3 2SC2855 or 2SC930
- Q4 2SC2649 or 2SC930
- D1-D3 1SV103 or 1SV55

NOTES
 ALL RESISTORS ARE IN OHMS 1/4 WATTS UNLESS OTHERWISE NOTED
 ALL CAPACITORS ARE IN μ F/50V UNLESS OTHERWISE NOTED
 ELECTROLYTIC CAPACITORS (E) ARE IN μ F/WV
 ALL DIODES ARE 1SS133 or 1SS104 or 1S2076D or 1S243 UNLESS OTHERWISE NOTED.
 ALL PNP TRANSISTORS ARE 2SA1015-QR or 2SA733-P UNLESS OTHERWISE NOTED.
 ALL NPN TRANSISTORS ARE 2SC1815-QR or 2SC945A-P UNLESS OTHERWISE NOTED.
 THE COMPONENTS IDENTIFIED BY MARK Δ ARE CRITICAL FOR SAFETY. REPLACE ONLY WITH PART NUMBER SPECIFIED.
 *VOLTAGE MEASURED WITH V.T.V.M. V IS DC VOLTAGE (NO INPUT SIGNAL)
 *CIRCUIT IS SUBJECT TO CHANGE FOR IMPROVEMENT.

- D902 ϕ P10144003 or 144003F
- D903 H25.6E82 or 05A26-BY
- D904 H25.6E82 or 05A25-6Y
- D713 H25.1E82 or 05A25-1Y

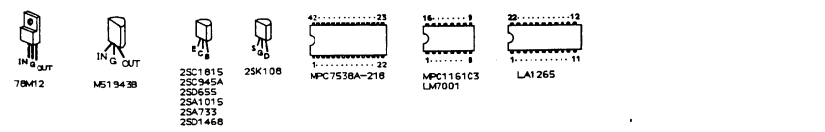
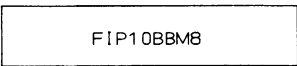

PRINTED CIRCUIT BOARD—PARTS LIST

FM/AM TUNER CIRCUIT PC BOARD(NARF-3261-1/A/ B)

CIRCUIT NO.	PART NO.	DESCRIPTION	CIRCUIT NO.	PART NO.	DESCRIPTION
	Front end				
TU001	240080	FE306-A27 <D>	C112	354780109	1 μ F,50V,Elect.
	240074	FE407G <G/W>	C114	354741009	10 μ F,16V,Elect.
	ICs		C118,C120	354784799	0.47 μ F,50V,Elect.
Q103	222912	LA1265	C121	354742209	22 μ F,16V,Elect.
Q201	222678	μ PC1161C3	C153	354780109	1 μ F,50V,Elect.
Q701	22240090	LM7001	C155,C157	354741009	10 μ F,16V,Elect.
Q705	222951	M-51943B	C156,C119	354780479	4.7 μ F,50V,Elect.
Q901	222780122	78M12	C160	354782299	0.22 μ F,50V,Elect.
	Transistors		C161	354741019	100 μ F,16V,Elect.
Q101	2211723	2SC1923-O	C202	354780479	4.7 μ F,50V,Elect.
Q102	2211723	2SC1923-O <G/W>	C203	354744179	479 μ F,16V,Elect.
Q104,Q106	2211255 or	2SC1815-GR or	C205,C206	354741009	10 μ F,16V,Elect.
Q205	2210746	2SC945A-P	C210	370134714	470pF \pm 5%,100V,APS
Q105,Q703	2211255	2SC1815-GR	C211	354780109	1 μ F,50V,Elect.
Q151,Q202	2211455 or	2SA1015-GR or	C212	354780339	3.3 μ F,50V,Elect.
Q801	2210803	2SA733-P	C213	354782299	0.22 μ F,50V,Elect.
Q203,Q204	2211705,	2SD655-E,	C219,C220	354780339	3.3 μ F,50V,Elect.
	2211706 or	2SD655-F, or	C701	354722219	220 μ F, 6.3V,Elect.
	2212794	2SD1468-R	C707,C710	354780229	2.2 μ F,50V,Elect.
Q702	2212294	2SK108-D	C708	354782299	0.22 μ F,50V,Elect.
	Diodes		C903	335251039	0.01 μ F, 500V,Ceramic
D101,D102	223132	1K60	C904	354784709	47 μ F,50V,Elect.
D103-D106	223163	1SS133	C905	354761029	1000 μ F,35V,Elect.
D201,D204	223150,	US1040,	C908	354744709	47 μ F,16V,Elect.
	223145 or	1S2076TD or	C909	354722219	220 μ F, 6.3V,Elect.
	223124	1S2473	C910	354764709	47 μ F,35V,Elect.
D202,D203	223163	1SS133	C911	354762219	220 μ F,35V,Elect.
D701,D704	223163	1SS133	C912	354761019	100 μ F,35V,Elect.
D707	223163	1SS133 <W>		Resistors	
D713	224650512 or	HZ5.1EB2 or	R101	5215046	N08HR50KBC,Semi-fixed
	224150512	05AZ5.1Y	R201	5215044	N08HR5KBC,Semi-fixed
D801,D802	223163	1SS133	R902	441621204	12ohm,1W,Metal oxide film
D803	224650562 or	HZ5.6EB2 or	R903	441523314	330 ohm,1/2W,Metal oxide film
	224150562	05AZ5.6Y	R905	441629104	91 ohm,1W,Metal oxide film
D901	223862 or	WL01 or		Terminals	
	223890	W01RL	P101	25060085	NTM-4PDMN29,Antenna <D>
D902	223880 or	GP101N4003 or		25060117	NTM-2PDML051, Antenna <G/W>
	223896	1N4003F	P102	25045182	NPJ-2PDBL72 <D>
D903	224650682 or	HZ6.8EB2 or		25045211	NPJ-4PDBL91 <G/W>
	224150682	05AZ6.8Y	P103	25045172	HSJ1003-01-020
D904	224650562 or	HZ5.6EB2 or		Switch	
	224150562	05AZ5.6Y	S701	25065286	NSS-22112,Band <W>
	Transformers				
L101	233394	NFIF-4068			
L102	233395	NFIF-4069			
L152	232139	NMIF-4062			
	Coils				
L001	223312	NFA-3051 <G>			
L103	231081	NCH-2129			
L201	233383	NMC-6070 <G/W>			
L202,L203	233355A	NMC-4059			
	RF block				
L151	232138	NMRF-7046			
	Ceramic filters				
X101,X102	3010071	SFE10.7MA5 (RED) <D>			
X101-X103	3010137	SFE10.7MMK <G/W>			
X151	3010123	SFZ450JL			
X152	3010076	BFU450C			
	X'tal				
X701	3010073	XTL-7.2M			
	Capacitors				
C002	354741019	100 μ F,16V,Elect.			
C107	354744709	47 μ F,16V,Elect.			
C111	354780229	2.2 μ F,50V,Elect.			

NOTE: <D>:Only 120V model
 <G>:Only 220/240V models
 <W>:Only Worldwide model

PRINTED CIRCUIT BOARD PARTS LIST

DISPLAY PC BOARD(NADIS-3262-1/1A/1B)

CIRCUIT NO.	PART NO.	DESCRIPTION
	IC	
Q751	22240152	# PD7538ACU-218
	Fluorescent tube	
Q752	212053	FIP10BBM8
	Diodes	
D751	223163	1SS133
D752	224650912 or 224150912	HZ9.1EB2 or 05AZ9.1Y
D753-D757	223163	1SS133
D758-D766	223150, 223145 or 223124	US1040, 1S2076TD or 1S2473
D767	223163	1SS133 <D/W>
D768	223163	1SS133 <D>
	Osc. element	
X751	3010138	CSB600P,Ceramic
	Capacitors	
C751	354780109	1 # F,50V,Elect.
C755	395160107	1 # F,35V,Tantalum
C756	3020027 or 3000051	0.047F,5V or 0.047F,5.5V,Super
C757	354721019	100 # F, 6.3V,Elect.
	Resistor	
R754	49163103405	10 kohm \times 5,1/10W,Network
	Switches	
S751-S763	25035548	NPS-111-S510
	Cushion	
	28140738	

SWITCH PC BOARD(NAAF-3263-1)

CIRCUIT NO.	PART NO.	DESCRIPTION
S764-S767	25035548	NPS-111-S510,Push switches

POWER SUPPLY CIRCUIT PC BOARD(NAPS-3264-1/1A/1B/1C)

CIRCUIT NO.	PART NO.	DESCRIPTION
T901	2300287	△ NPT-990D,Power transformer <D>
	2300288	△ NPT-990G,Power transformer <G>
	2300290	△ NPT-990Q,Power transformer <Q>
	2300289	△ NPT-990DG,Power transformer <W>
C901	3500065A	△ DE7150FZ 103PAC400V/125V,Capacitor IS
	27300601	△ Cover for C901 <G/W/Q>
R901	431523355	△ 3.3Mohm,1/2W,Solid resistor <D>
S901	25035558	△ NPS-111-L520P,Power supply
	28175137	Insulated plate

NOTE: <D>:Only 120V model
 <G>:Only 220V model
 <W>:Only Worldwide model
 <Q>:Only 240V model

NOTE: THE COMPONENTS IDENTIFIED BY MARK △ ARE
 CRITICAL FOR RISK OF FIRE AND ELECTIC
 SHOCK. REPLACE ONLY WITH PART NUMBERS
 SPECIFIED.

[ONKYO CORPORATION

International Division: No. 24 Mori Bldg., 23-5, Nishi-Shimbashi 3-chome, Minato-ku,
 TOKYO 105, JAPAN Tel: 03-432-6987 Fax: 03-436-6979 TLX: 242-3551 ONKYO J
ONKYO U.S.A. CORPORATION
 200 Williams Drive, Ramsey, N.J. 07446, U.S.A. Tel: 201-825-7950 Fax: 201-825-8150